

BRACKET BH6AM

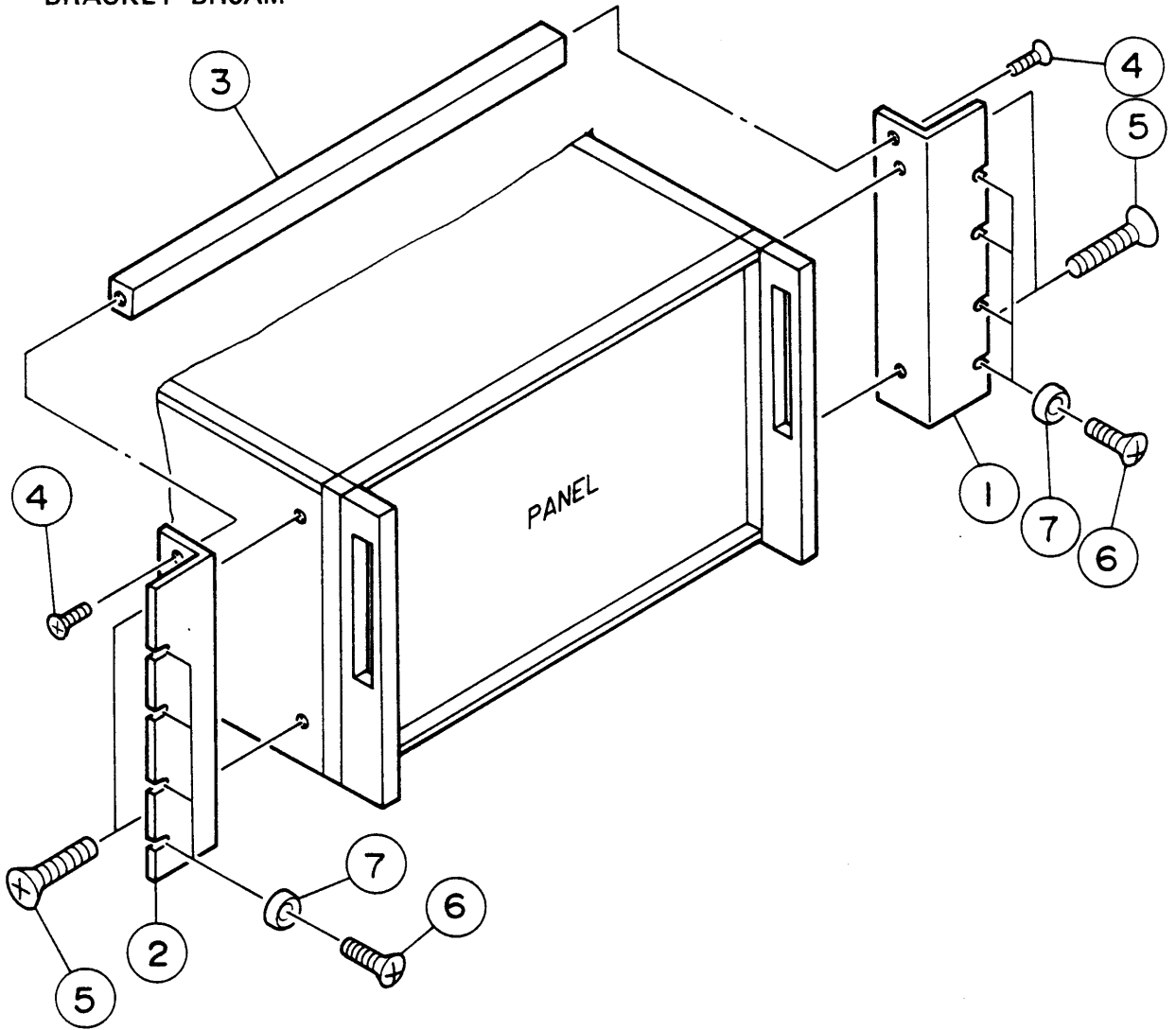

NO.	DESCRIPTION	QTY	CODE NO.
1	BRACKET RIGHT BH6AM MM-SISE	1	D3-912-501
2	BRACKET LEFT BH6AM MM-SISE	1	D3-912-502
3	BAR 8x430 BH6AM	1	G8-912-501
4	SCREW, FLAT HEAD M3x0.5x10 S-ZN	2	M2-001-101
5	SCREW, FLAT HEAD M6x1x25 S-ZN	4	M2-001-213
6	SCREW, OVAL HEAD M5x0.8x14 B-NI	8	M2-002-091
7	FINISHING WASHER 5CW	8	M5-003-031